

Parts, Service kits & Accessories

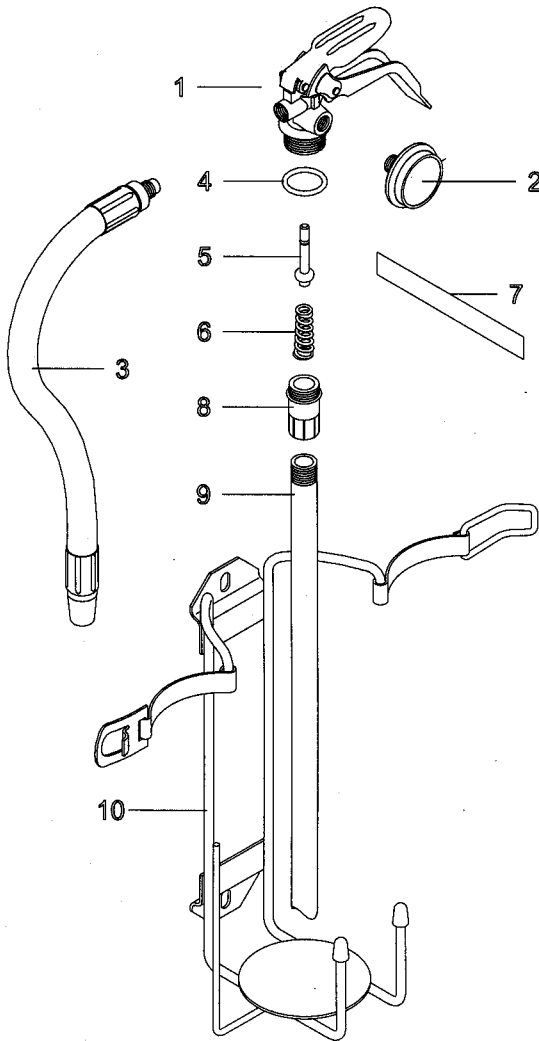

2.0 kg Extinguisher

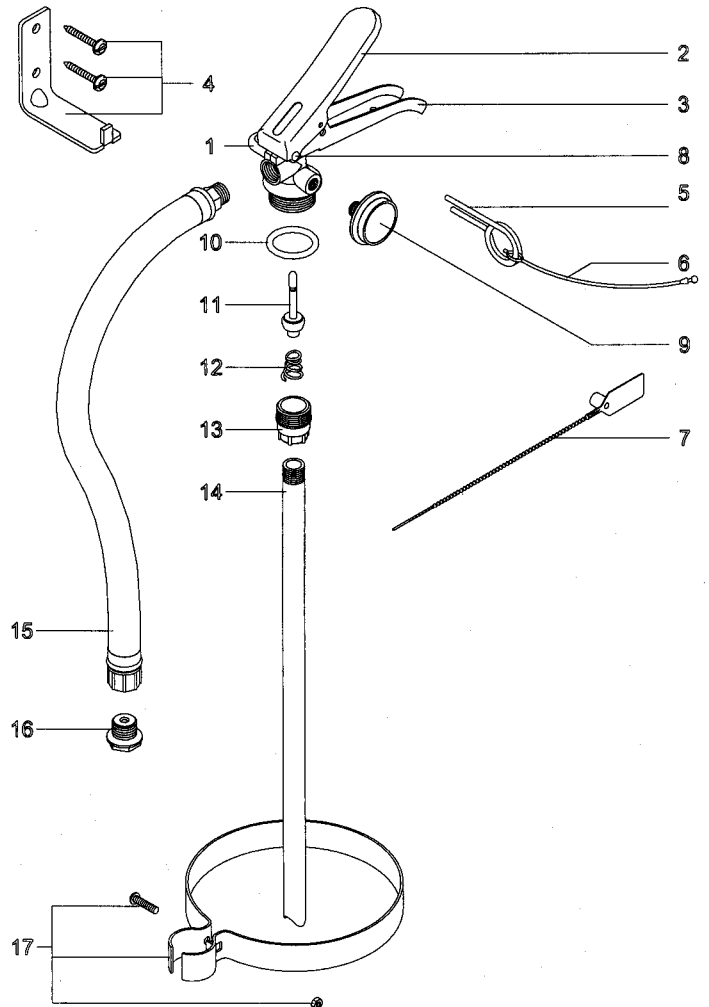

4.5 & 9.0 kg Extinguisher

Parts 2.0 kg		
Fig.	Part No.	Description
1	02075	Valve Assembly - 2.0 kg
2	02090	Pressure Gauge 1035 kPa - 2.0 kg
3	02100	Hose Assembly - 2.0 kg
4	02101	Neck Seal 'O' Ring - 2.0 kg
5	02076	Check Stem Assembly - 2.0 kg
6	02102	Valve Spring - 2.0 kg
7	02232	Handle Safety Seal
8	02103	Siphon Tube Adaptor Nut - 2.0 kg
9	02104	Siphon Tube - 2.0 kg
10	02079	Mounting Bracket - 2.0 kg
N/S	03660	Main Label - 2.0 kg

Service Kits - 2.0 kg		
Fig.	Part No.	Description
N/S	00785	Valve Kit - contains "Check Stem Assembly, Valve Spring, Neck Seal 'O' Ring".

Service Kits - 4.5 9.0 kg		
Fig.	Part No.	Description
N/S	00784	Valve Kit - contains "Check Stem Assembly, Valve Spring, Neck Seal 'O' Ring".
N/S	00786	Handle Kit - contains "Operating Lever, Support Handle, Rivet".

Parts 4.5 & 9.0 kg		
Fig.	Part No.	Description
1	02074	Valve Assembly - 4.5 & 9.0 kg
2	02081	Operating Lever - 4.5 & 9.0 kg
3	02082	Support Handle - 4.5 & 9.0 kg
4	02080	Wall Bracket Pack - 4.5 & 9.0 kg
5	02078	Safety Pin - 4.5 & 9.0kg
6	02094	Safety Pin Tie - 4.5 & 9.0 kg
7	01177	Anti Tamper Seal - 4.5 & 9.0 kg
8	02083	Handle Rivet - 4.5 & 9.0 kg
9	02091	Pressure Gauge 1345 kPa - 4.5 & 9.0 kg
10	02092	Neck Seal 'O' Ring - 4.5 & 9.0 kg
11	02077	Check Stem Assembly - 4.5 & 9.0 kg
12	02093	Valve Spring - 4.5 & 9.0 kg
13	02095	Siphon Tube Adaptor Nut - 4.5 & 9.0 kg
14	02096 02097	Siphon Tube - 4.5 kg Siphon Tube - 9.0 kg
15	02066 02067	Hose Assembly - 4.5 kg (less Nozzle) Hose Assembly - 9.0 kg (less Nozzle)
16	02069 02070	Nozzle - 4.5 kg Nozzle - 9.0 kg
17	02098 02099	Hose Retainer Bracket - 4.5 kg Hose Retainer Bracket - 9.0 kg
N/S	03661	Main Label - 4.5 kg
N/S	03662	Main Label - 9.0 kg